

# VENTILATEURS

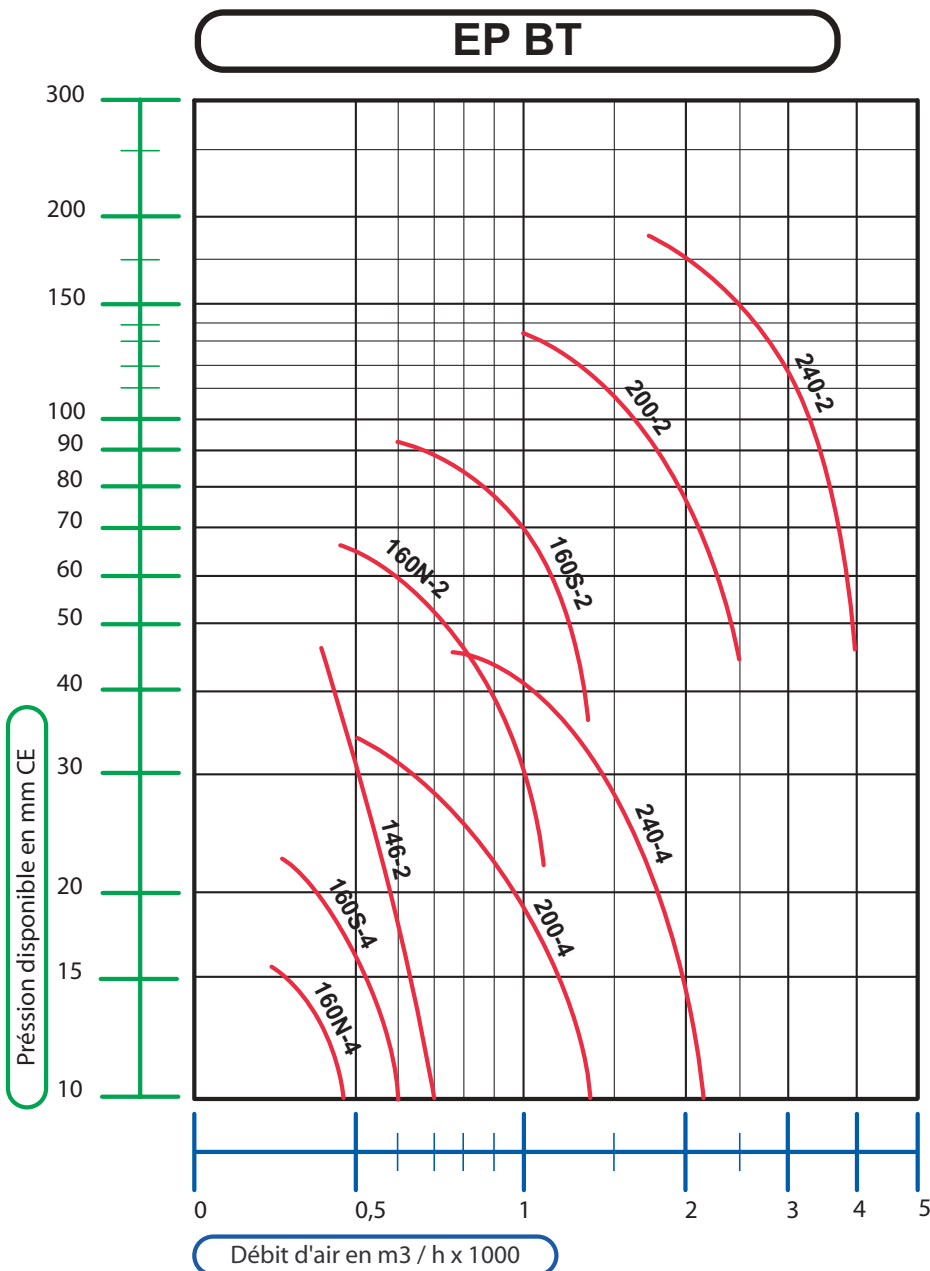

## VENTILATEURS CENTRIFUGES EP-BT

- Série EP-BT.



# VENTILATEURS



## VENTILATEURS CENTRIFUGES EP-BT

- Série EP-BT.

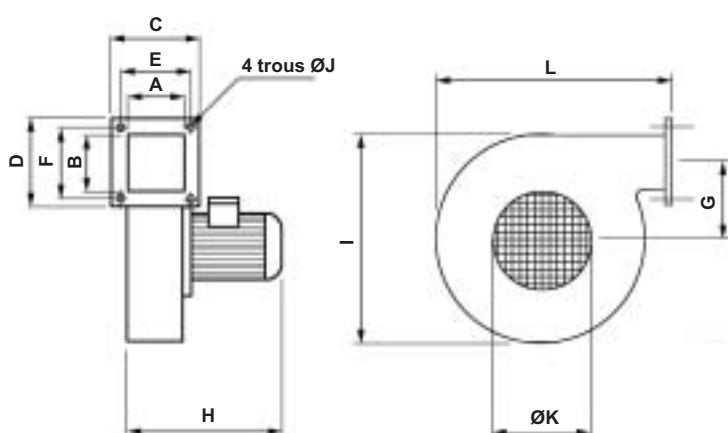

Types	A	B	C	D	E	F	G	H	I	J	ØK	L
EP-BT 146-2	90	90	133	133	112	112	93	277	248	8,5	64	252
EP-BT 160N-2	113	124	160	170	140	145	88	314	263	8,5	83	269
EP-BT 160S-2	123	113	170	160	149	128	115	324	300	8,5	83	293
EP-BT 200-2	135	135	190	190	164	164	141	363	373	8,5	113	333
EP-BT 240-2	162	173	222	233	194	205	160	434	438	8,5	113	400
EP-BT 160N-4	113	124	160	170	140	145	88	300	263	8,5	134	269
EP-BT 160S-4	123	113	170	160	149	128	115	310	300	8,5	134	293
EP-BT 200-4	135	135	190	190	164	164	141	336	373	8,5	168	333
EP-BT 240-4	162	173	222	233	194	205	160	390	438	8,5	187	400

### CARACTERISTIQUES EP-BT

Type	Puissance (kW)	tr/mn	dBA à 3 m	Prix HT
<b>EP-BT : 1 vitesse triphasé 230/400V</b>				
146-2	0,18	2820	64	292,32 €
160N-2	0,37	2800	70	311,36 €
160S-2	0,55	2800	72	319,20 €
200-2	1,10	2840	76	471,52 €
240-2	2,20	2865	83	736,96 €
160N-4	0,18	1350	54	314,72 €
160S-4	0,18	1350	54	315,84 €
200-4	0,25	1380	59	421,12 €
240-4	0,55	1380	68	713,44 €

