

# MOTEURS ELECTRIQUES

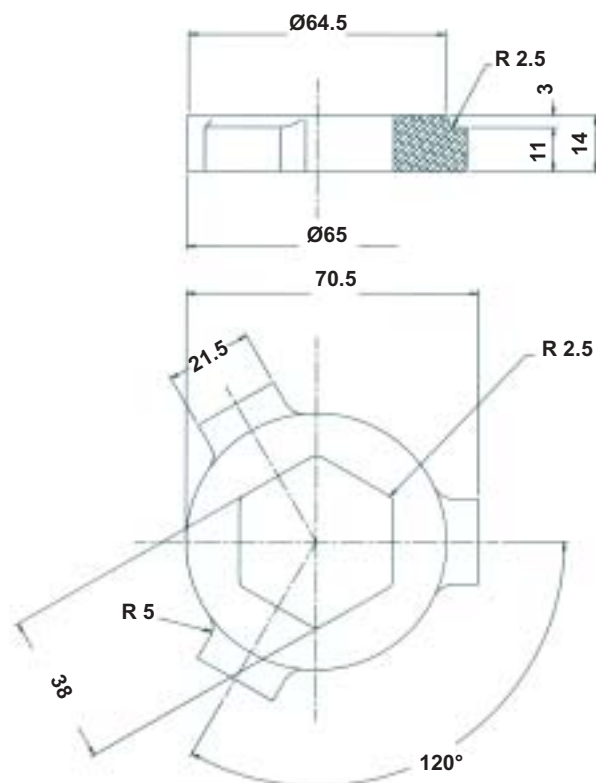

## BAGUES CAOUTCHOUC

- Pour moteurs ouverts et fermés S et P ou Alexmar.

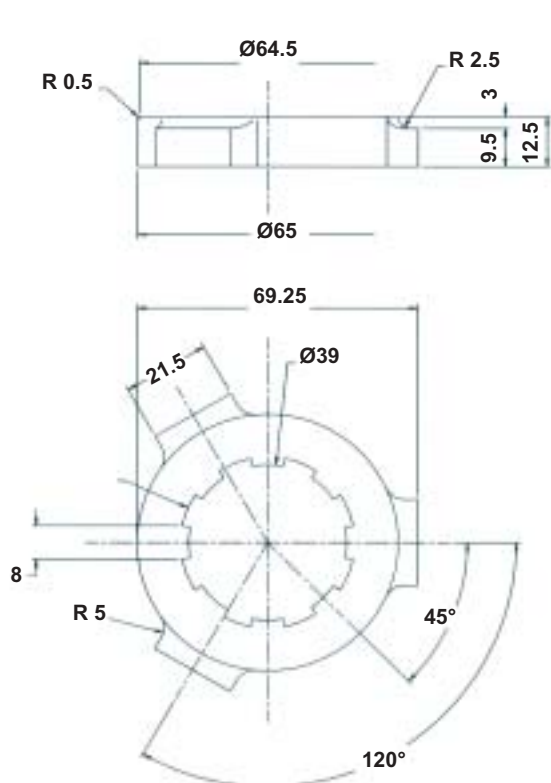

Type	Prix HT
C055001 40 SH Blanc	3,67 €
C055002 60 SH Gris	2,92 €
C055003 80 SH Noir	2,48 €

Type SP Hexagonal	Prix HT
C055201	3,02 €



# MOTEURS ELECTRIQUES



## BAGUES CAOUTCHOUC

- Pour moteurs ouverts et fermés S et P ou Alexmar.

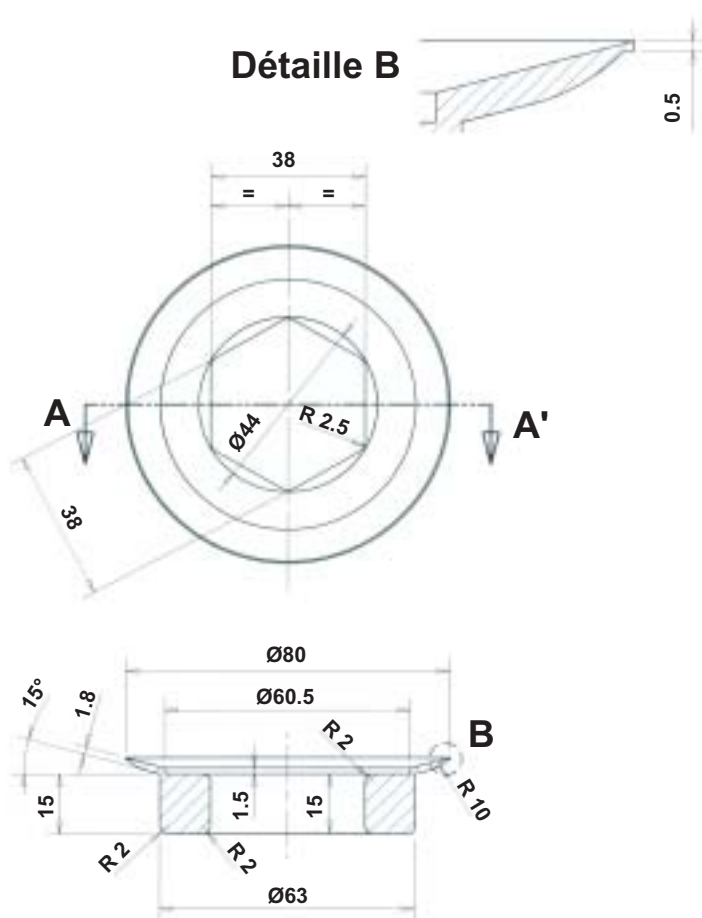
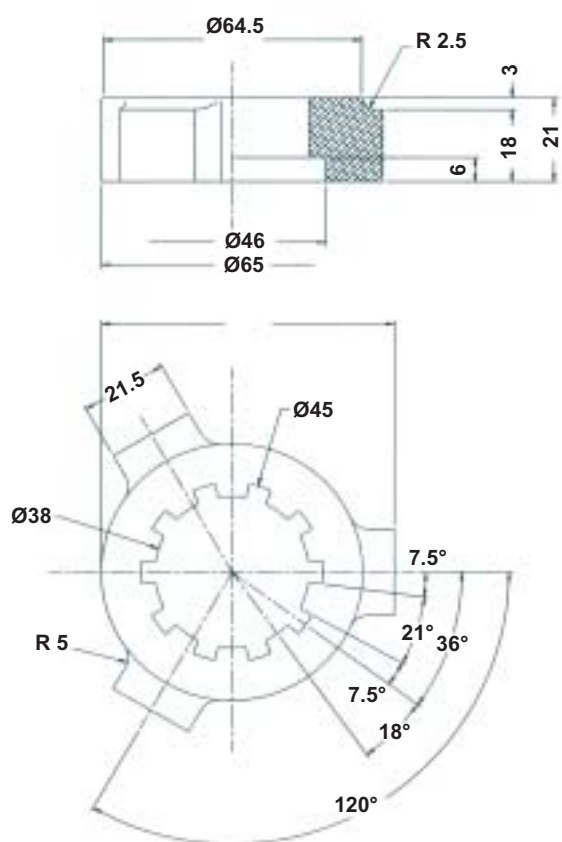

Type SP Denté	Prix HT
C055202	4,104 €

Type S et P	Prix HT
C055203	3,132 €

